

*Southwest Microwave, Inc.*

Security Systems Division

---

**INTREPID™**

MicroWave 330-33461

A DIGITAL MICOWAVE  
OUTDOOR PERIMETER INTRUSION DETECTION SYSTEM

---

MicroWave 330-33461 Installation  
and Operation Manual



## **Trademark Notice and Certifications**

INTREPID™, MicroPoint™ and MicroTrack™ are registered trademarks of Southwest Microwave, Inc. Copyright 1995 and 2012 Southwest Microwave, Inc. All rights Reserved.

### **CE Notice**

This equipment has been designed and tested to EN300 440, EN301 489-3, EN60950-1:206 + A12: 2011 and AS/NZS 4268.

### **RoHS Compliant**

**Copyright Southwest Microwave, Inc. December 2012**

**Southwest Microwave, Inc.  
9055 South McKemy Street  
Tempe, Arizona 85284-2946**

**Tel: (480) 783-0201**

**Fax: (480) 783-0401**

**Email: [infossd@southwestmicrowave.com](mailto:infossd@southwestmicrowave.com)**

**Web: [www.southwestmicrowave.com](http://www.southwestmicrowave.com)**

## **INTREPID™ MicroWave 330-33461 Software**

Southwest Microwave, Inc. thanks you for your purchase of the INTREPID MicroWave 33033461 Digital Microwave Intrusion Link. Please refer to the Universal Installation Service Tool II (UIST II) for the software setup of this sensor.

One disk is required to setup the system. It is called:

Universal Installation Service Tool II (UIST II)

This software is used to configure and set-up the system as well as being used for maintenance and troubleshooting the system.

*Software provided by Southwest Microwave, Inc. is subject to the license agreement terms of the individual product. A copy of the license agreement is available by contacting Southwest Microwave, Inc.*

# Table of Contents

<b>1. Introduction.....</b>	<b>5</b>
<b>2. Hardware.....</b>	<b>5</b>
2.1 MicroWave 330-33461 Link .....	5
2.2 Optional Power Supplies .....	6
2.3 Optional Accessories .....	6
<b>3. Principles of Operation and Detection.....</b>	<b>6</b>
3.1 Description.....	6
3.2 Range of Operation.....	7
3.3 Overlaps.....	8
3.3.1 High Security Overlaps .....	9
3.4 Transmitter Block Diagram .....	9
3.5 Receiver Block Diagram.....	10
3.6 Specifications.....	11
<b>4. Installation Instructions .....</b>	<b>13</b>
4.1 Location of MicroWave 330-33461 .....	13
4.1.1 Required Area.....	13
4.1.2 Terrain .....	14
4.1.2.1 Terrain in High Security Applications .....	14
4.1.3 Physical Protection .....	15
4.1.4 Best Security.....	15
4.2 Mounting of MicroWave 330-33461 .....	16
<b>5. Modes of Operation .....</b>	<b>18</b>
5.1 Free Running Mode .....	18
5.2 Tethered Mode.....	19
<b>6. Wiring .....</b>	<b>20</b>
6.1 Power Supply Wiring .....	20
6.2 Communications Wiring.....	21
6.3 Tethered Wiring.....	21
6.4 Synchronized Wiring.....	22
6.5 Remote Test.....	23
<b>7. Terminals, Switches and Indicators .....</b>	<b>24</b>
7.1 MicroWave 330-33461 Transmitter .....	24
7.1.1 Channel Select Switch .....	24
7.1.2 External / Internal Modulation Switch .....	24
7.2 MicroWave 330-33461 Receiver.....	25
7.2.1 Address Switch .....	26
7.1.2 Audio Alarm Switch.....	26
7.2.3 Communications Ports.....	26
<b>8. Connecting the Transmitter and Receiver.....</b>	<b>26</b>
8.1 MicroWave 330-33461 Transmitter Connections .....	26
8.2 MicroWave 330-33461 Receiver Connections.....	27
<b>9. Alignment and Testing .....</b>	<b>27</b>
<b>10. Preventive Maintenance .....</b>	<b>28</b>
<b>11. Limited Warranty.....</b>	<b>29</b>
<b>12. Returning Equipment under Warranty.....</b>	<b>29</b>
<b>13. Returning Equipment fro Non-Warranty Repair.....</b>	<b>30</b>
<b>14. Replacement Parts .....</b>	<b>30</b>

## 1.0 Introduction

The MicroWave 330-33461 is part of the INTREPID™ Series II family of products. It is an integrated volumetric perimeter detection system for open areas, gates, entryway, walls and rooftop applications. It provides volumetric detection of human intruders with minimal environmental nuisance alarms. Advanced digital signal processing (DSP) allows continuous monitoring of intrusion alarm and tamper switch status, received signal strength for path fault and detection parameters. A system controller such as the Relay Control Module II (RCM II), Control Module II (CM II), Graphic Control Module II-HD (GCM II-HD), Perimeter Security Manager (PSM) or SDK (Software Development Kit) is required to poll and configure alarm sources from MicroWave 330 for annunciation.

MicroWave 330-33461 operates at K-band (24.162 GHz) frequency, achieving superior performance to X-band sensors. Because K-band is 2.5 times higher the X-band, the multipath signal generated by an intruder is more focused, and detection of slow-moving intruders is correspondingly better. At K-band frequency, the unit also has low susceptibility to outside interference from air/seaport radar or other common microwave devices.

MicroWave 330-33461 communicates with other INTREPID Series II devices (AIM II, ROM II, PM II and MTP II) using RS422 communications. This communication can be done over 22 or 24 gauge stranded shielded twisted pair wire (max 5,000 feet [1,500m] between devices) or with fiber optic devices. The address of each MicroWave 330-33461 is set by a dip switch on the receiver circuit board.

MicroWave 330-33461 operates from 10.5 to 60 VDC @ 2.0 Watts (each unit) with a minimum startup current of 250mA. The operating currents with standard power supplies are: 12 VDC @ 170mA (Tx) / 208mA (Rx), 24 VDC @ 83mA (Tx) / 104mA (Rx) and 48 VDC @ 42mA (Tx) / 52mA (Rx).

## 2.0 Hardware

### 2.1 MicroWave 330-33461 Digital Microwave Link

Each MicroWave 330-33461 Digital Microwave Link includes a MicroWave 330-33461 Transmitter, Microwave 330-33461 Receiver and two MB62 Universal Mounting Brackets as shown in Figure 1.

MicroWave 330-33461 dimensions are 10.6 in diameter (270mm) and 10.125 in (257mm) front to back (from radome face to mounting bracket). Each unit weighs 4.5 lbs (2.041kg).



*Figure 1 – MicroWave 330 Hardware*

## 2.2 Optional Power Supplies

**12 VDC power supply:** Model PS13 Power Supply operates from 85-246VAC, 47-63Hz and furnishes 13.6 VDC at up to 2.8A. Power supplies contain automatic switchover and battery charging circuitry for optional standby batteries of up to 25AH. Temperature rated from 14° to 122° F (-10° to 50° C). UL, ETS, EMC, CE, RoHS compliant.

**12 VDC power supplies:** Model PS40 Power Supply operates from 120 VAC, 50-60Hz, 0.5A and furnishes 13.7 VDC at up to 1.6A. Model PS41 Power Supply operates from 220 VAC, 50-60Hz, 0.25A. Both contain automatic switchover and battery charging circuitry for optional standby batteries of up to 25AH and are fused on both input and output for maximum protection. Temperature rated from -40° to 150° F (-40° to 66° C).

**24 VDC power supply:** Model 78B1064 operates from 120VAC to provide 24VDC at 5A with 6.5AH battery backup. Includes; indoor enclosure 15 x 11 x 4 in. (381 x 280 x 102mm). Temperature rated from 32° to 122° F (0° to 50° C).

**48 VDC power supplies:** Model PS48 operates from 120VAC to provide 48VDC at 3A. Includes; indoor enclosure 14 x 12 x 4 in. (356 x 305 x 102mm). Model PS49 operates from 220VAC to provide 48VDC at 3A. *This supply does not include enclosure.* Temperature rated from 32° to 122° F (0° to 50° C). UL, CSA, TUV, CE compliant.

## 2.3 Optional Accessories

**MB65 Mounting Bracket:** Model MB65 is a heavy duty, position locking non-corrosive mounting bracket for a 4 inch (102mm) O.D. post.

**RS14 Radome:** Model RS14 is a shielded radome used to add additional RFI/EMI protection for Microwave 330-33461 transmitter and receiver.

**48C15529-A01 Enhanced Reflector:** Model 48C15529-A01 is an optional reflector to provide a shorter “dead zone” to MicroWave 330-33461 transmitter and receiver. This option reduces max range to 400 feet (122m).

**02A15483-A01 Radome Latch Kit:** Model 02A15483-A01 replaces the 6 radome screws for quicker access to the sensor electronics. Two kits are required for each MicroWave 330-33461 Digital MicroWave Link.

**JB70A:** Lightning/Surge Protection module protects the data communications and power lines. Includes; enclosure with terminal strips for wire connections.

## 3.0 Principles of Operation and Detection

### 3.1 Description

The MicroWave 330-33461 Transmitter radiates amplitude modulated K-band energy that travels to the MicroWave 330-33461 Receiver where it is detected. A microprocessor and proprietary algorithms provide powerful Digital Signal Processing to recognize the unique bi-static digital signatures of intruders walking, jumping, running or crawling through the detection field. Targets are classified and scored in real time at each sensor and stored in the receiver’s flash memory. When an intruder approaches the beam the energy at the receiver changes in signal amplitude directly related to the targets size and density allowing the sensor to discriminate between targets. MicroWave 330-33461 will alarm on average sized humans walking, running or crawling on hands and knees through the detection pattern. Field adjustments can provide alarm on larger or smaller targets, depending on the specific site requirements. Operation of MicroWave 330-33461 is illustrated in Figure 2.

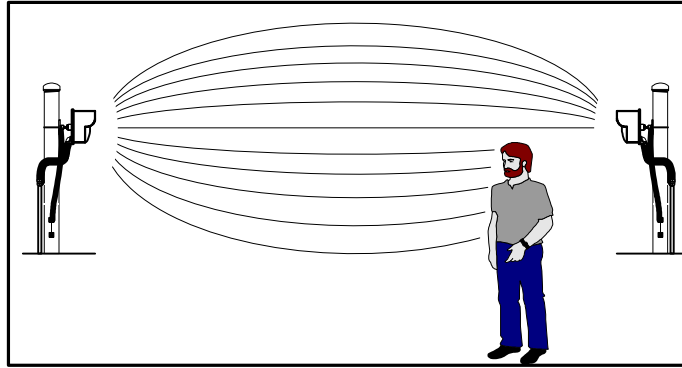

Figure 2 – Operation of MicroWave 330 Link

### 3.2 Range of Operation

A single MicroWave 330-33461 may cover a distance of 800 feet (244m). The receiver is equipped with automatic gain control (AGC), which automatically adjusts receiver for the distance to be covered and sets the Path Fault parameter.

Typical maximum width protection pattern of MicroWave 330-33461 is shown in Figure 3 for mounting height of 3 feet (.91m) above smooth earth. Maximum width will be when Transmitter-Receiver distance is at maximum and Receiver “Gain” (sensitivity) control is set to maximum.

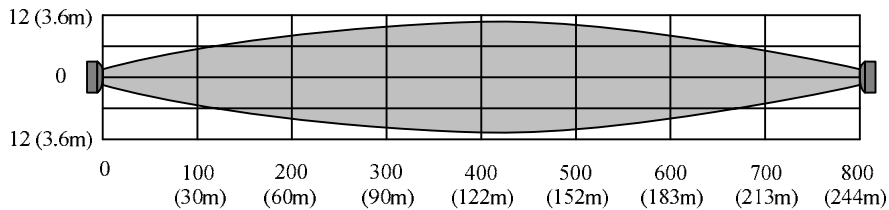

Figure 3 – Typical Maximum Horizontal Pattern

Figure 4 illustrates how pattern width varies with Transmitter-Receiver distance and gain setting. Actual patterns will vary somewhat with site topography and surface condition. Generally, lower mounting height or rougher surface will increase pattern width. For example, if the total link distance is 400 feet (122m) and the gain adjustment set to 10, the detection pattern width will be 6 feet (1.8m), half of the maximum width.

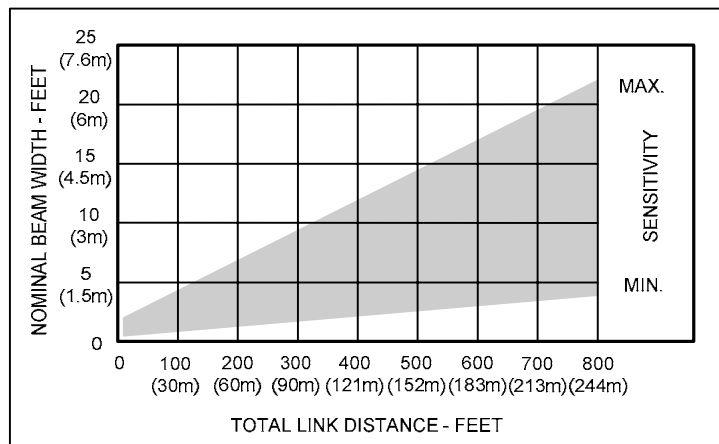

Figure 4 – Typical Maximum Horizontal Pattern

Vertical protection pattern will also depend upon Transmitter-Receiver distance, mounting height and “Gain” setting. Actual patterns will vary somewhat with site topography and surface condition. Typical pattern height is 50 to 75% of pattern width. Approximate vertical protection pattern is shown in Figure 5. For example, at 50 feet (15m) with minimum sensitivity the pattern height is 5 feet (1.5m).

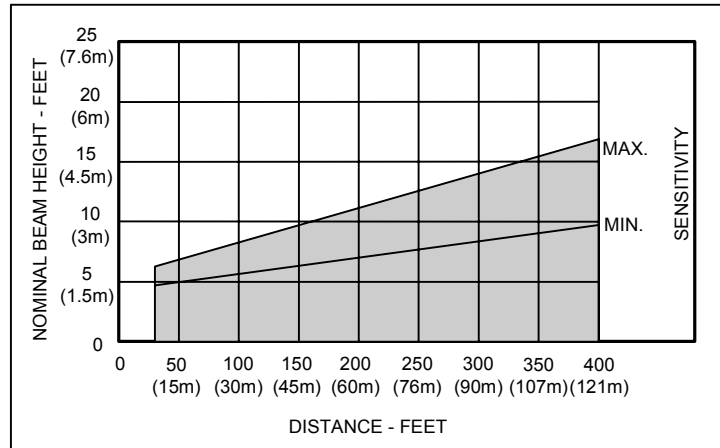

Figure 5 – Typical Vertical Pattern

### 3.3 Overlaps

Protection pattern below centerline will tend to fill area between beam centerline and ground except for a “dead zone” immediately in front of and below Transmitter and Receiver. This zone is best protected by overlapping links at ends and corners as shown in Figures 6.

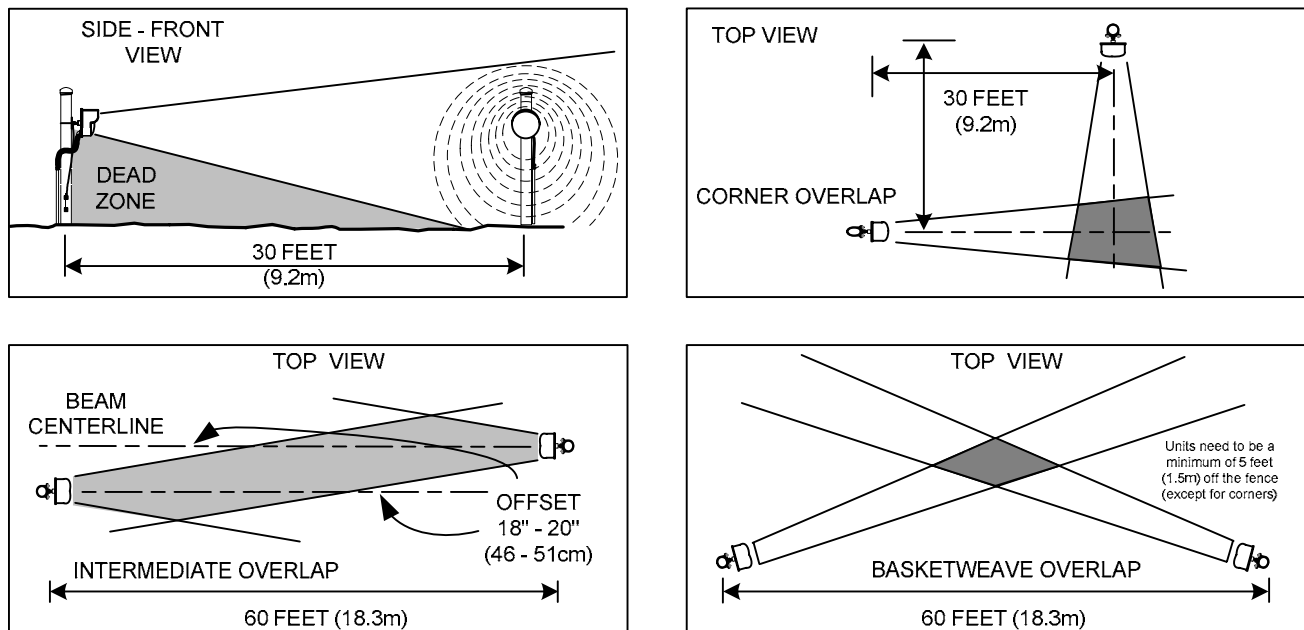

Figure 6 – Overlaps and Dead Zone

Corner overlaps should be 30 feet (9.2m) minimum. Intermediate or in line overlaps should be 60 feet (18.3m) minimum with a beam centerline offset of 18 to 20 inches (46-51cm). Basket weave overlaps should be 60 feet (18.3m) minimum and a minimum of 5 feet (1.5m) off the fence (except for corners).



Figure 7 shows amount of overlap required to detect against hands and knees crawling intruders, as a function of “Sensitivity” setting. It is always recommended to keep the sensitivity setting at the lowest possible value to minimize nuisance alarms but maintaining a high probability of detection.

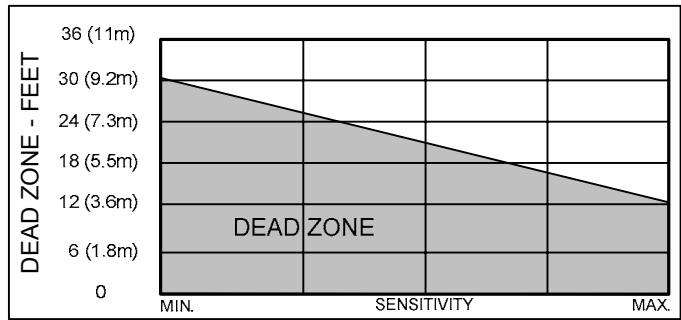

Figure 7 – Sensitivity vs Dead Zone

### 3.3.1 High Security Overlaps

For maximum-security applications where detection of prone “commando style” crawl is required, the intermediate over-lap should be 60 feet (18.3m) minimum with parallel beam centerline offset of 18 inches (46cm) maximum. The corner overlaps should be 30 feet (9.2m) minimum. Terrain flatness should be no more than plus three inches or minus three inches deviation from a plane drawn between the transmitter and receiver. The zone length (Transmitter to Receiver) should not exceed 400 feet (122m). Typical zone lengths do not exceed 328 feet (100m). Nominal mounting height should be 30 inches (762mm)

High security applications also use stacked link configurations to meet site requirements. A stacked link may consist of two or more MicroWave 330-33461 links or used in combination with the Model 300B link which operates at X-band frequency of 10.525 GHz. A stacked link greatly reduces the dead zone and increases PD.

### 3.4 Transmitter Block Diagram

MicroWave 330-33461 Transmitter consists of two major subassemblies – RF Assembly and Transmitter Circuit Board. A block diagram is shown in Figure 8.

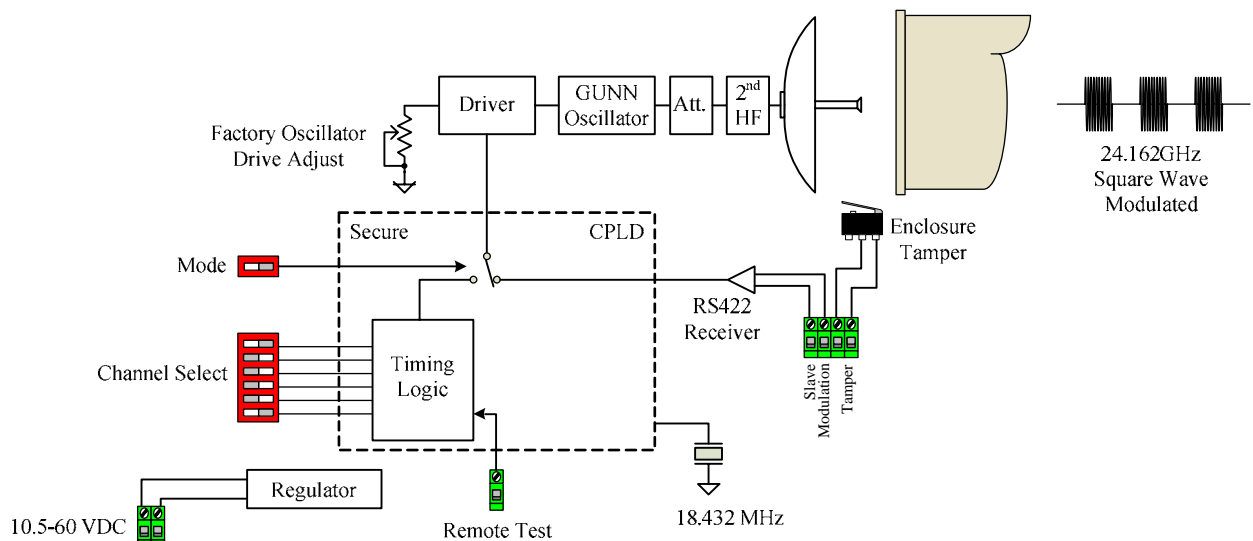

Figure 8 – MicroWave 330-33461 Transmitter

The RF assembly consists of a Gunn oscillator, which generates K-band microwave energy and the parabolic antenna system. The Transmitter circuit board contains voltage regulator and modulation circuit to drive the microwave oscillator and a secure CPLD. Modulation frequency in Un-Tethered Mode is selected from one of six channels (A, B, C, D, E, and F) by a dip switch on the Transmitter Circuit Board.

The CPLD is responsible for the generation of the asynchronous modulation frequencies when the “Mode” switch is set to “Internal” position and also for determining the quality of the signal provided on the tether when the “Mode” switch is set to “External” position.

A “Test” terminal is provided on the Transmitter Circuit Board. Application of 5.0 to 14.0 VDC will cause Transmitter to turn off and illuminate the red “Channel Error” LED, generating a test alarm at receiver. A green LED on Transmitter Circuit Board indicates that power is on.

### 3.5 Receiver Block Diagram

MicroWave 330-33461 Receiver consists of two major subassemblies – RF Assembly and Receiver Circuit Board. A block diagram is shown in Figure 9.

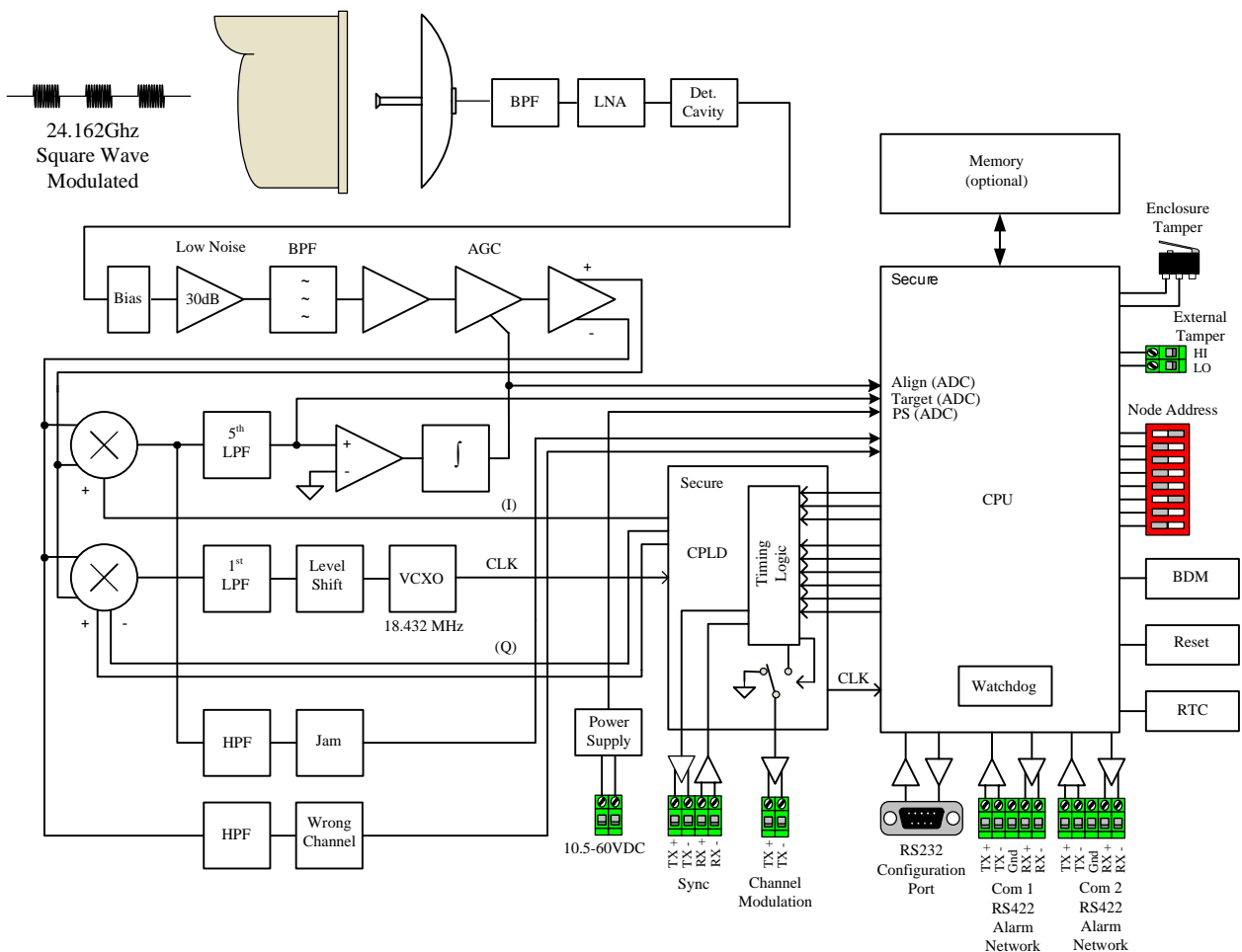

Figure 9 – MicroWave 330-33461 Receiver

MicroWave 330-33461 Receiver RF Assembly consists of a parabolic antenna (identical to antenna of Transmitter) and a Schottky diode detector. The detector converts modulated K-band energy from Transmitter into a low frequency signal for processing by Receiver Circuit Board.

The received audio signal is amplified by an automatic gain control (AGC) preamplifier enabling the preamplifier output to be held to a constant level regardless of Transmitter Receiver distance (distance must be within maximum distance of link). This also sets the “Align/Path Fault” alarm parameter.

The detector output is a voltage level that is held constant under normal conditions by the slow-acting AGC loop. Rapidly changing signal strength caused by a target moving into the microwave beam is not affected by AGC loop and causes an AC signal to appear at the detector output. Signal is amplified, filtered, digitized and compared with detection parameters.

Whenever signal matches the detection parameters, an alarm is generated. “Gain” (sensitivity) is adjusted in the UIST II software program.

Microwave 330-33461 Receiver is equipped with various alignment and troubleshooting features. Alignment voltage test point provides a DC voltage proportional to received signal strength that may be measured with an ordinary VOM. It is usually viewed in the UIST II software program.

A red “Alarm” LED lights whenever an intrusion occurs. A red “Wrong Channel” LED lights whenever Transmitter and Receiver are set to different modulation channels. A red “Jam” LED lights when a secondary interfering signal is present. A red “Pulse” LED indicates the application program is running. There are also LED’s for communications status of the RS422 and RS232 ports.

## **3.6 Specifications**

### **1.0 Detection Capability**

- 1.1 Range: 100 feet (30.5m) to 800 feet (244m).
- 1.2 Beam Diameter: 2 feet (.6m) to 22 feet (6.7m) depending upon link distance and “Gain” setting per Figure 4.
- 1.3 Target: 77 pound (35kg) human – walking, running, hands and knees crawling or jumping. Prone crawling or rolling 77 pound (35kg) human or simulated with a 12-inch (30cm) diameter metal sphere detected at maximum range of 400 feet (122m) with flat terrain.
- 1.4 Minimum Target Velocity: 0.1ft. /sec. (30mm/sec.)
- 1.5 Maximum Target Velocity: 50ft. /sec. (15m/sec.).

### **2.0 Reliability**

- 2.1 Equipment False Alarm Rate: 1/year/unit based upon signal-to-noise ratio at maximum sensitivity setting.
- 2.2 Probability of Detection: 0.99% minimum on 77-pound (35kg) human upright or on hands and knees.
- 2.3 Self Supervision: Alarm on failure (inherent in design, fully self-supervised) and remote test.

- 2.4 Automatic Gain Control: Link automatically adjusts to slow changes in path loss due to environment. AGC range: -60dB.
- 2.5 Cross Modulation: When installed in accordance with following installation instructions cross modulation (interference) from adjacent links will be 25dB below primary signal.

### **3.0 Transmittal Signal**

- 3.1 Radiated Power: +20dBm peak EIRP, square wave modulated.
- 3.2 Carrier Frequency: K-band (24.162 GHz).
- 3.3 Modulation Frequencies: Six field-selectable modulation frequencies.
- 3.4 Above specifications for CE are in accordance with EN300 440. This equipment has been designed and tested to EN301 489-3, EN60950-1:2006 +A12:2011 and AS/NZS 4268.

### **4.0 Power Requirement**

- 4.1 Voltage: 10.5 to 60.0VDC 2.5W maximum (Tx or Rx).
- 4.2 Current: Transmitter and Receiver under normal ambient operating conditions:  
12 VDC: Tx @ 170mA – Rx @ 208mA  
24 VDC: Tx @ 083mA – Rx @ 104mA  
48 VDC: Tx @ 042mA – Rx @ 052mA
- 4.3 Transmitter fused for 0.25 amps and Receiver fused for 0.5 amps.

### **5.0 Alarm Indication**

- 5.1 Red Alarm LED.
- 5.2 Red Jam LED.
- 5.3 Red Wrong Channel LED.
- 5.4 Audible alarm with Sonalert.
- 5.4 Tamper Switch, Transmitter and Receiver: Form C contacts rated 2.0 amps at 28 VDC.

### **6.0 Alignment and Test Aids**

- 6.1 Alignment Voltage: Available in software or at Receiver Test Point. Positive voltage, suitable for 100,000 ohms/volt VOM, increases with receiver signal strength. Range 0.5-5.0 VDC.
- 6.2 Wrong Channel LED: Red LED on Receiver board lights when Transmitter and Receiver set to different channels.
- 6.3 Jam LED: Red LED on Receiver board lights when receiver is receiving multiple RF sources.
- 6.4 Pulse LED: LED on Receiver board blinks showing the application software is running.

- 6.5 Communication LED's: Green LED's on Receiver board to indicate RS422 and RS232 transmit and receive communication polls.
- 6.6 Transmitter "ON" LED: Green LED on Transmitter circuit board indicates that power is on.
- 6.7 Channel Error LED: Red LED on Transmitter to indication Tx/Rx set to different modulation channel or Remote Test is on.

**7.0 Communications Ports**

- 7.1 1 - RS232 configuration port. 2 – RS422 communications ports.

**8.0 Weight, Transmitter, or Receiver: 4.5 pounds (2.04kg). Shipping weight 18 pounds (8.2kg)**

**9.0 Operating Environment**

- 8.1 Temperature: -40° F to +150° F (-40° C to +66° C)
- 8.2 Relative Humidity: 0 to 100%.

**10.0 Dimensions (Transmitter or Receiver)**

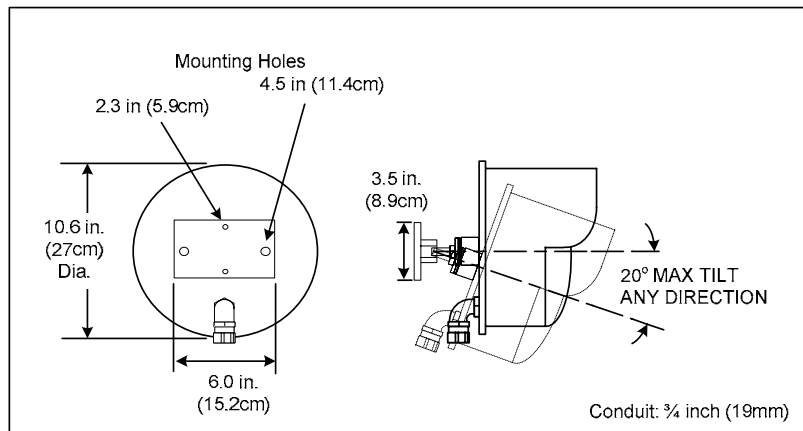

*Figure 10 – MicroWave 330-33461 Transmitter or Receiver Dimensions*

**4.0 Installation Instructions**

**4.1 Location of Microwave 330**

**4.1.1 Required Area**

MicroWave 330-33461 must be located in an area which is free of obstructions and moving objects such as chain link fences parallel to the detection field, trees, bushes and large areas of water as shown in Figure 11. Large moving objects within the protection pattern will be indistinguishable from an intruder and will cause nuisance alarms.

The clear area required for a MicroWave 330-33461 installation depends upon the distance to be covered by the link. Protection patterns for various conditions are given in Figures 4. In each installation the clear area must be at least as large as the maximum protection pattern.

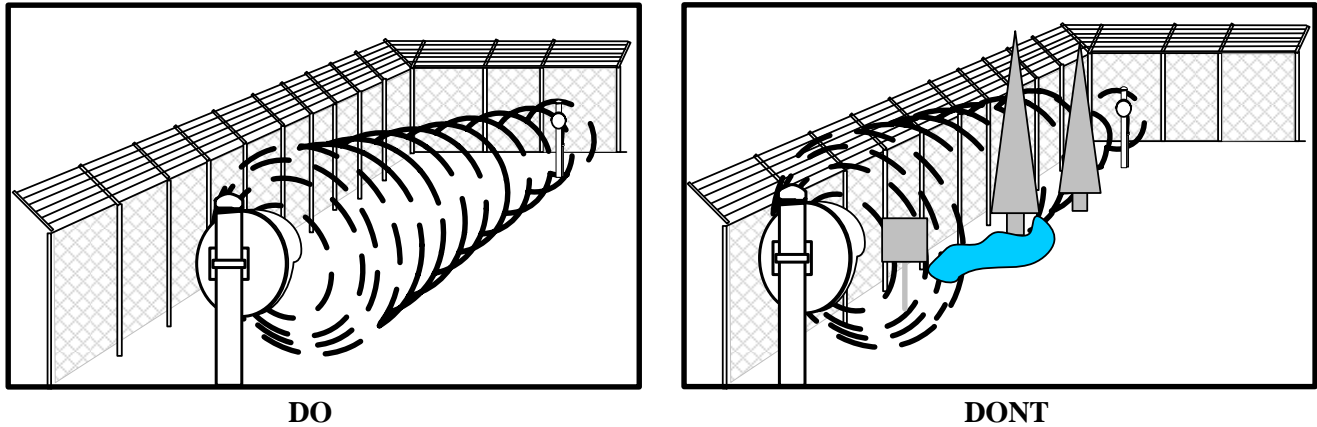

Figure 11 – Clear Area

#### 4.1.2 Terrain

Since the operation of Link requires transmission of energy from Transmitter to Receiver, it is important to maintain a clear line of sight between the units. Therefore, the ground must be flat across the protected area. Any bumps, hills or ditches in the area will shadow the beam and may provide crawl space for an intruder. Bumps or hills must be leveled, and ditches filled so that the area is flat to within six (6) inches (152mm) as shown in Figure 12.

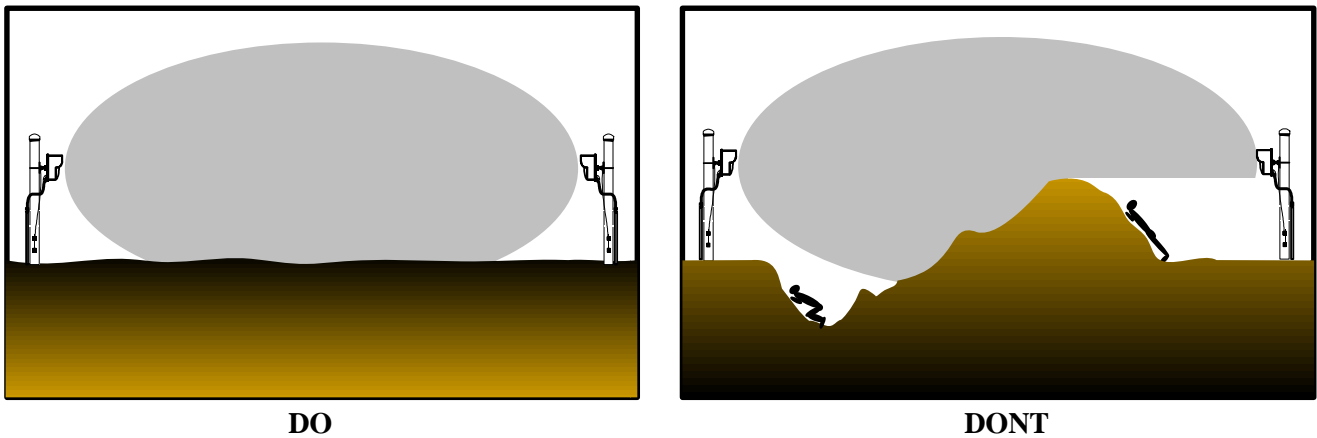

Figure 12 – Terrain

The protected area can be any stable, reasonably smooth material such as concrete, asphalt, tilled earth or gravel. If there is grass or vegetation in the protected area it must be kept cut to a maximum of three (3) inches (76.2mm) in height. Snow accumulation should not exceed three (3) inches (76.2mm) in height. MicroWave 330-33461 should not be operated over open water.

##### 4.1.2.1 Terrain in High Security Applications

For maximum-security applications where detection of prone “commando style” crawl is required, the terrain flatness should be no more than plus three inches or minus three inches deviation from a plane drawn between the transmitter and receiver. The zone length (Transmitter to Receiver) should not exceed 400 feet (122m).

### 4.1.3 Physical Protection

Install the Transmitter and Receiver in locations that provide protection from accidental damage as well as from tampering. Simple devices such as bumper posts or parking guards may be used to protect equipment from damage from vehicles as shown in Figure 13.

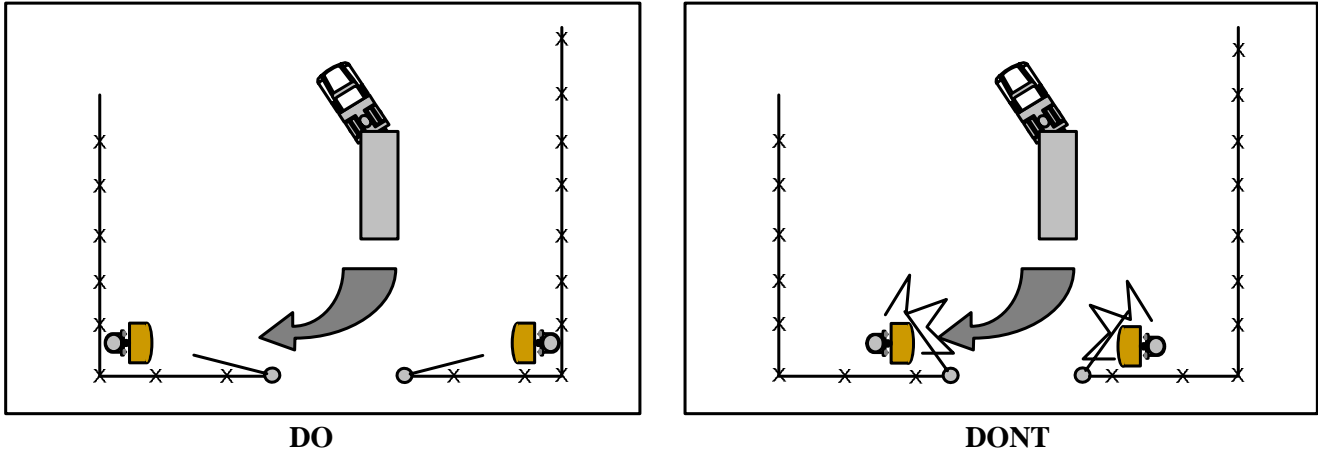

Figure 13 – Physical Protection

### 4.1.4 Best Security

Choose the location that will provide best security, yet be free from nuisance alarms. Always locate MicroWave 330-33461 inside a controlled access area to prevent unwanted nuisance alarms due to random foot traffic, vehicles, or large animals. Typically, units should be mounted 2 ½ to 3 feet (0.76-0.91m) above ground level, and far enough inside fence to provide a clear area of protection as shown in Figures 14 & 15.

For maximum security it is necessary to overlap the ends of links so that the dead spot below and immediately in front of the adjoining link is protected. A 60-foot (18m) overlap is recommended at intermediate points, and a 30-foot (9.2m) overlap is recommended at corners. If site demands shorter overlap, increased sensitivity will reduce dead zone, per Figure 7, but will also widen beam, per Figure 4. The offset of overlapping links in line should be 18 inches (46cm) as shown in Figure 6. Additional protection may be added at critical points by installing SOUTHWEST MICROWAVE, INC. Model 380 or 385 Transceiver, Model 415 PIR, MS15/MS16 Dual Tech sensor or stacking MicroWave 330-33461 links or stacking with Model 300B microwave link.

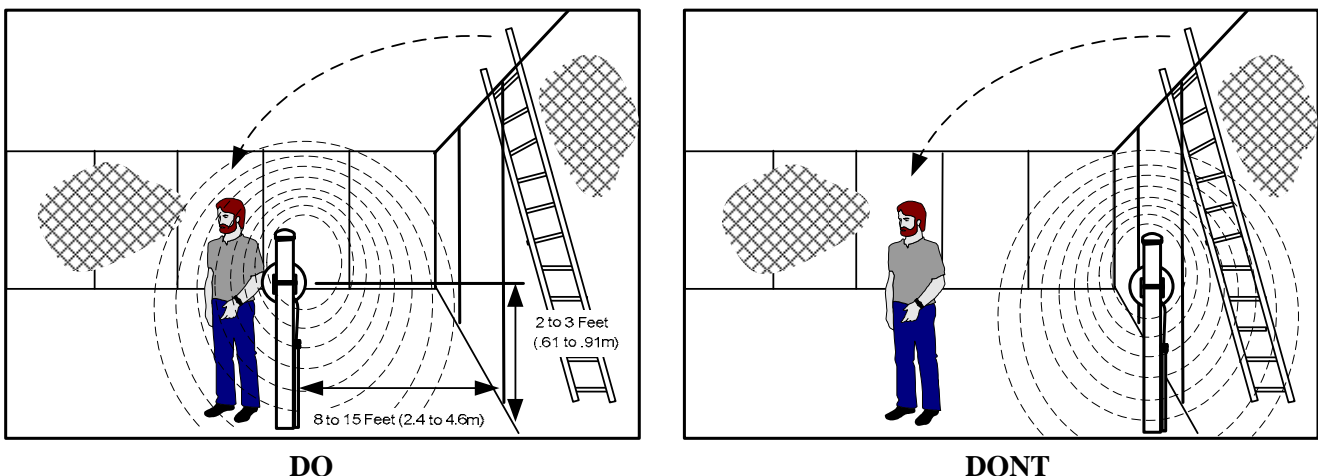

Figure 14 – Best Security

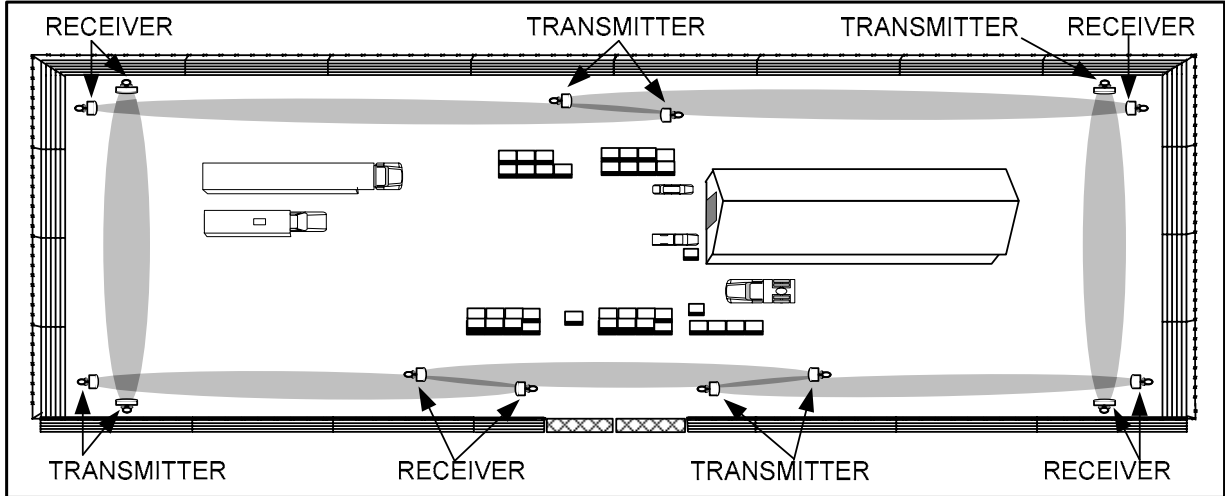

Figure 15 – Overlapping Links

Note from Figure 15 that at each point of overlap either two Transmitters or two Receivers are installed. This arrangement prevents an adjacent Transmitter and Receiver from establishing an unwanted link across the short overlap distance. If there is an odd number of links in an installation, a transmitter and receiver will need to be overlapped. This should be done in a corner as shown in Figure 15. Alternatively the synchronization capability in MicroWave 330-33461 could be utilized.

## 4.2 Mounting Microwave 330

Prepare a rigid mounting surface for MicroWave 330-33461 Transmitter and Receiver as shown in Figure 16.

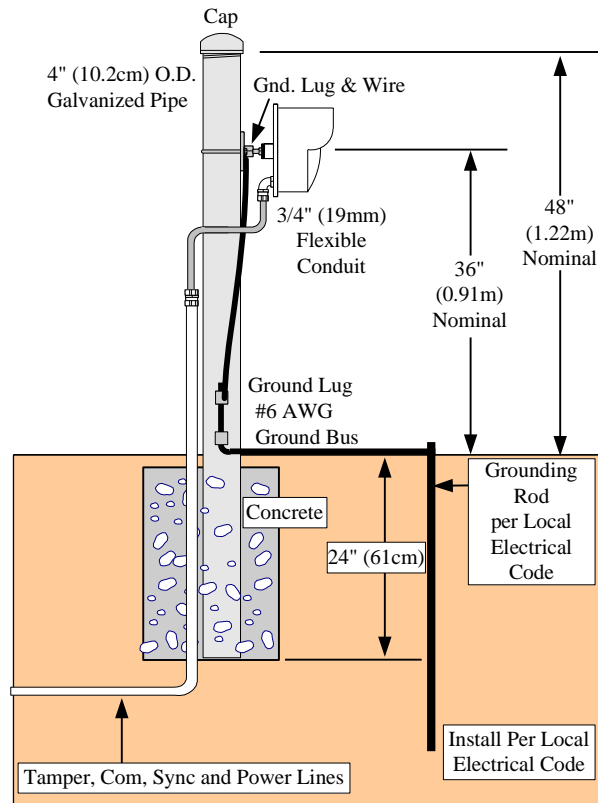

Figure 16 – Mounting Detail



Do not mount units on a cyclone fence or any vibrating surface. A recommended mounting post is a 3 ½ inch (89mm) galvanized pipe (outside diameter 4 inches, 102mm), sunk into the ground in a concrete base, and protruding above ground level to a height of 4 feet (1.2m). Mount the Transmitter and Receiver 2 ½ to 3 feet (0.76 to 0.91m) above ground level (dependent on detection requirements) and allow for height adjustment of at least plus or minus 6 inches (152mm). Height adjustment may be required during final alignment to achieve optimum protection pattern and signal strength. An 18-inch (457mm) ¾ inch (19mm) flex conduit is recommended between conduit fitting of T/R and rigid conduit.

### Stacking MicroWave 330-33461

For high security applications where “prone crawl” detection is required, the MicroWave 330-33461 can be stacked to provide a high probability of detection with a very low nuisance/false alarm rate and a reduction in dead zone as shown in Figure 17.

To eliminate mutual interference between links, one link can be rotated 90° to change the polarity from an E-plane (vertical polarization) to an H-plane (horizontal polarization) which will cross polarize the waveguides to eliminate potential interference. MicroWave 330-33461 includes synchronization circuitry that can also be utilized to eliminate potential interference.

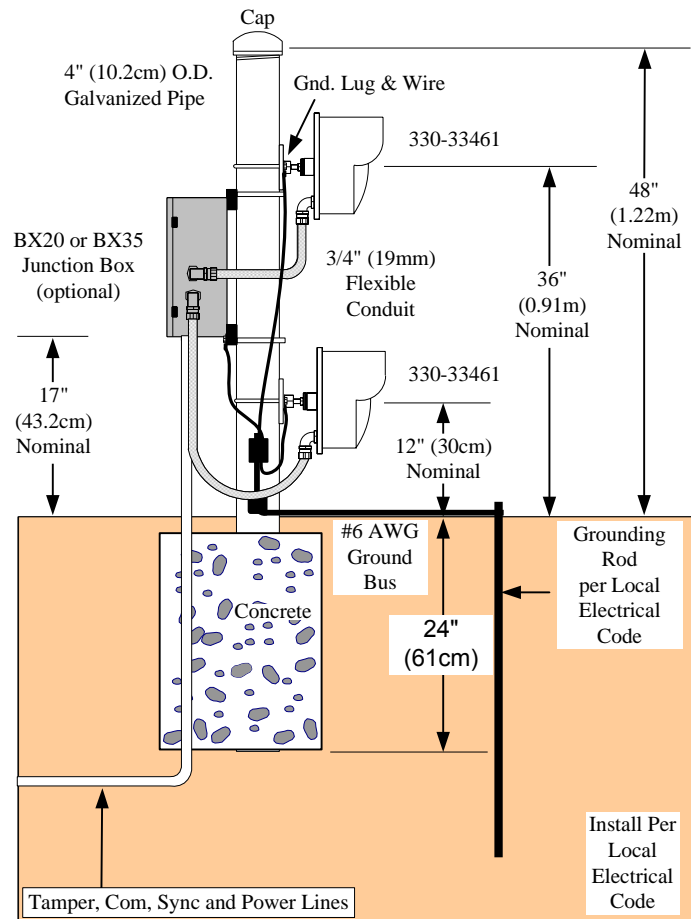

Figure 17 – Stacked Mounting Detail

1. Remove the MicroWave 330-33461 T/R Link(s) from the shipping containers. Separate the swivel assembly from the mounting plate by turning the large nuts counter-clockwise. Large nuts require 1 ¼ inch (32mm) open-end wrench.

2. Secure the mounting bracket to the post with U-bolt or to other mounting surface with appropriate screws or fasteners.
3. Secure the swivel assembly to MicroWave 330-33461 Transmitter and Receiver and attach to mounting bracket.
4. Rotate the MicroWave 330-33461 Transmitter and Receiver so that the conduit fittings are pointed straight down.
5. Tighten the large nuts on the swivel assembly to hold the units in place.

## 5.0 Modes of Operation

MicroWave 330-33461 has two modes of operation. One is the Un-Tethered configuration and the other is the Tethered configuration. The Tethered configuration is preferred as the link is in synchronous operation. In either configuration a controller is required for operation. The controllers that can be used are the Relay Control Module II (RCM II), Control Module II (CM II), Graphic Control Module II-HD (GCM II-HD), and Perimeter Security Manager (PSM) or a third party SDK development. See controller manuals for more information.

### 5.1 Un-Tethered Mode

In the Un-Tethered mode the controller and laptop are connected to the MicroWave 330-33461 receiver as shown in Figure 18. MicroWave 330-33461 setup and detection parameters are configured using the Universal Installation Service Tool II (UIST II) running on a laptop or desktop computer connected to the RS232 Configuration Port, Com 3. Alarm reporting is configured at the controller and is communicated on the RS422 alarm polling network, Com 1 and Com 2. If a CM II or GCM II-HD controller is used, MicroWave 330-33461 can be configured using the UIST II through the controller.

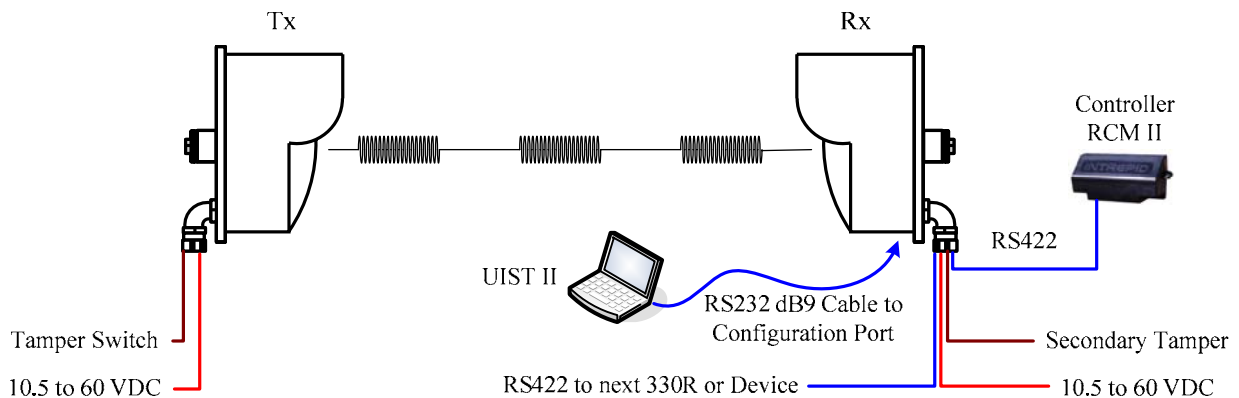

Figure 18 – Un-Tethered

In the Un-Tethered mode the MicroWave 330-33461 transmitter and receiver are independently configured. The transmitter and receiver must have their modulation channel set to the same modulation frequency. The tamper switch from the transmitter is monitored independently. The receiver has two tamper switches. One can be monitored over the alarm polling network and the other can be monitored independently. A typical Un-Tethered configuration using an RCM II as the controller and a Relay Output II (ROM II) module is show in Figure 19.

Optionally an AIM II can be used to monitor transmitter tampers. *Note: power wiring has been left off this example for clarity.*

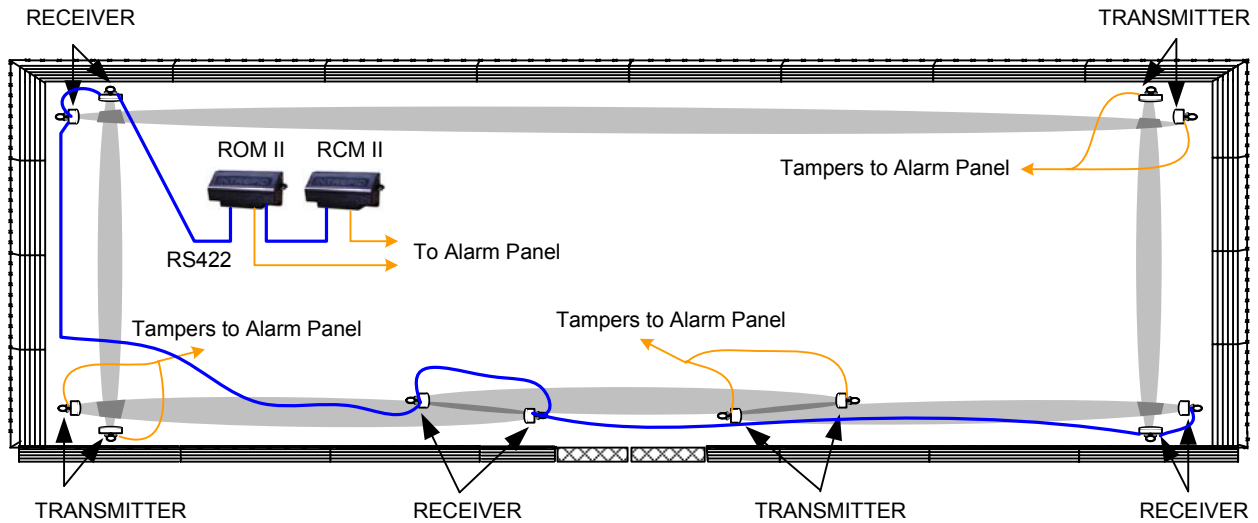

Figure 19 – Un-Tethered Example

## 5.2 Tethered Mode

In the Tethered mode the controller and laptop are connected to the MicroWave 330-33461 receiver as shown in Figure 20. MicroWave 330-33461 setup and detection parameters are configured using the Universal Installation Service Tool II (UIST II) running on a laptop or desktop computer connected to the RS232 Configuration Port, Com 3. Alarm reporting is configured at the controller and is communicated on the RS422 alarm polling network, Com 1 and Com 2. If a CM II or GCM II-HD controller is used, MicroWave 330-33461 can be configured using the UIST II through the controller.

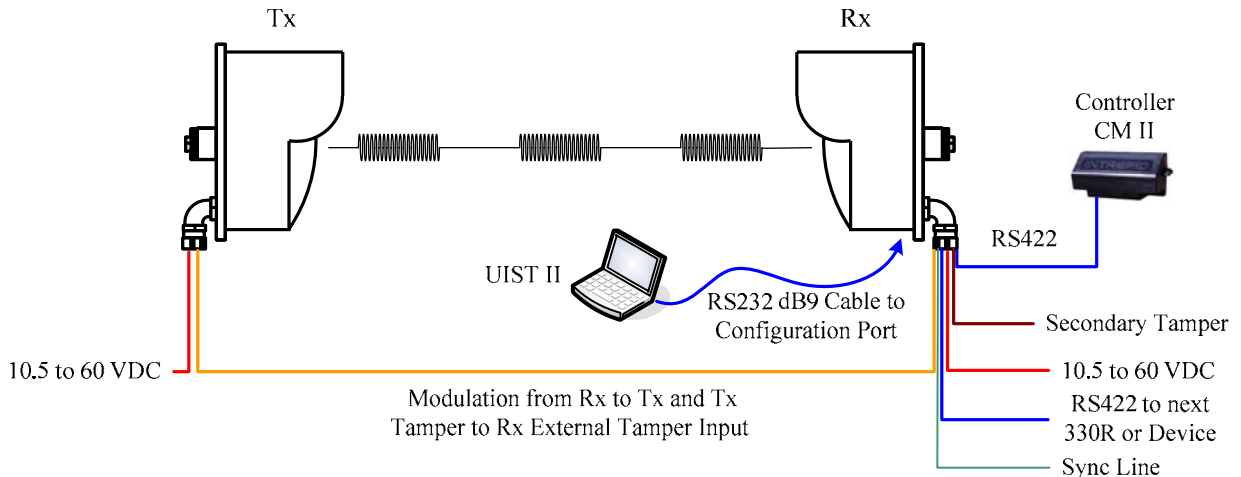

Figure 20 – Tethered Mode

The Tethered mode requires a wire connection between the transmitter and receiver for synchronous operation. The modulation signal from the receiver is provided on the tether to the transmitter and the transmitter tamper is wired into the External Tamper Input on the receiver so it is included in the alarm polling network. The tether also allows for changing the modulation frequency using the UIST II.

Also available in the tethered mode is synchronization. MicroWave 330-33461 incorporates synchronization circuitry that provides time division multiplexing so multiple links and Model 380 or Model 385 microwave transceivers can be used in close proximity without mutual interference. Two (2) MicroWave 330-33461 links and eight (8) transceivers can be connected on the sync line. Operational distance is limited to 750 feet (228m) in the synchronized mode.

A typical Tethered configuration using a CM II as the controller and a ROM II is show in Figure 21. *Note: power wiring has been left off this example for clarity.*

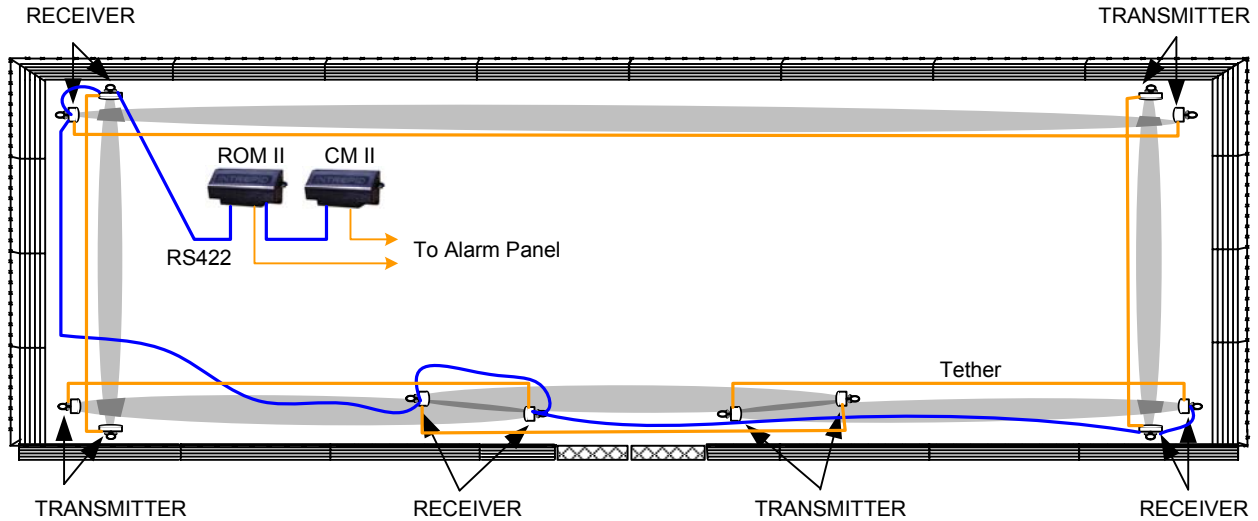

Figure 21 – Tethered Configuration

## 6.0 Wiring

### 6.1 Power Supply

MicroWave 330-33461 operates from 10.5 to 60 VDC @ 2.0W (each end). The operational current rating with standard power supplies are: 12 VDC @ 170mA Tx / 208mA Rx, 24 VDC @ 83mA Tx / 104mA Rx and 48 VDC @s 42mA Tx / 52mA Rx. Figure 22 shows the typical voltage drop for a 500 foot (152.4m) length of cable using various wire gauges.

WIRE GAUGE	VOLTAGE DROP PER 500 FT. (152.4m) TRANSMITTER			VOLTAGE DROP PER 500 FT. (152.4m) RECEIVER		
	12 VDC	24 VDC	48 VDC	12 VDC	24 VDC	48 VDC
# 14 AWG (1.63mm dia)	0.43V	0.21V	0.11V	0.52V	0.26V	0.13V
# 16 AWG (1.29mm dia)	0.68V	0.33V	0.17V	0.84V	0.42V	0.21V
# 18 AWG (1.05mm dia)	1.09V	0.53V	0.27V	1.33V	0.66V	0.33V
# 20 AWG (0.82mm dia)	1.72V	0.84V	0.42V	2.10V	1.05V	0.53V
# 22 AWG (0.66mm dia)	2.75V	1.34V	0.68V	3.37V	1.68V	0.84V

Figure 22 – Voltage Drop

## 6.2 Communications Wiring

Figure 23 shows the typical RS422 wiring diagram for the alarm polling network. This example uses the Relay Control Module II (RCM II) as the system controller connected to a Relay Output Module II-16 (ROM II-16) and a MicroWave 330-33461 receiver. The MicroWave 330-33461 is located on the perimeter. The RCM II and the ROM II-16 are located in the control room for relay output interface to other control room devices.

The communications is RS422 and must use a 22 or 24 gauge twisted, stranded, shielded pair wire. Fiber optic devices can be used as well. Since this RS422 communications format is a point to point configuration, no termination device is required for the last unit on the line.

All the RS422 communications wiring is from the transmit side of one device to the receive side of the next device with the wiring from TX + to RX + and TX - to RX - as shown in Figure 23.

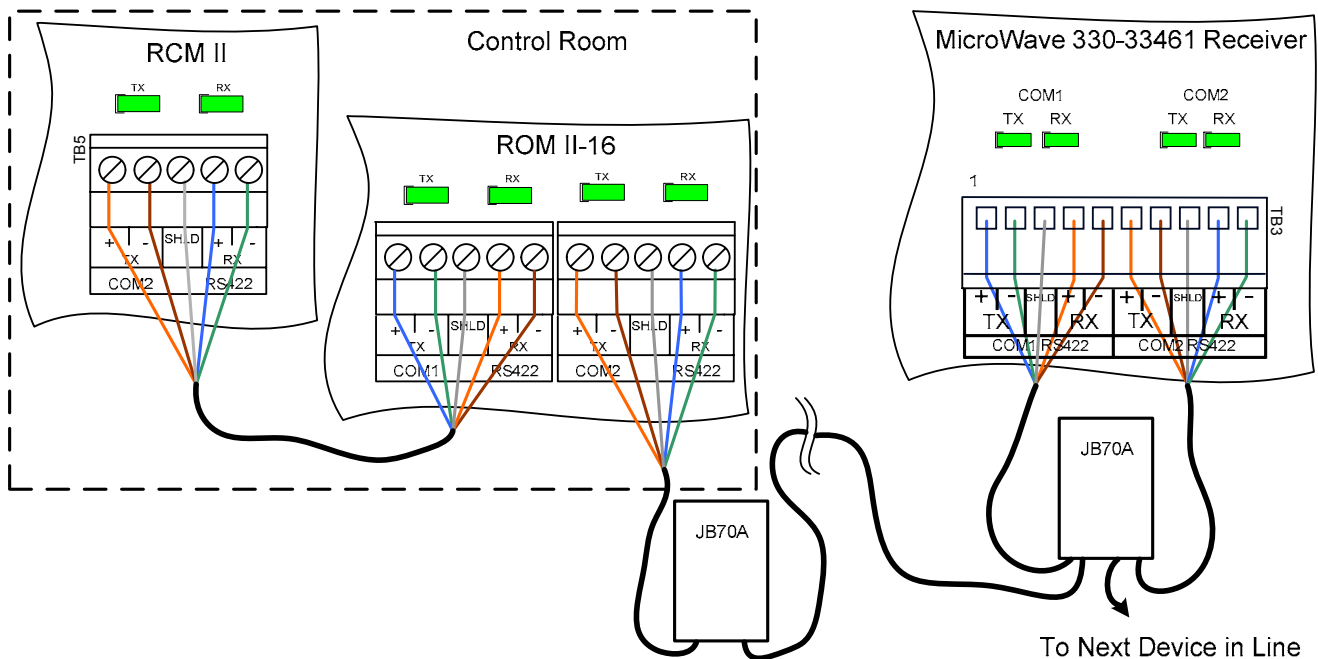

Figure 23 – MicroWave 330-33461 Communications Wiring

## 6.3 Tethered Wiring between Transmitter and Receiver

Figure 24 shows the typical wiring from MicroWave 330-33461 Transmitter to Receiver in the Tethered configuration. The “Mod Out” terminal from the receiver is connected to the “Modulation Input” terminal on the transmitter for synchronous operation. Switch S2 “Modulation” would be set to “External”. The “Tamper Switch” terminal from the transmitter is connected to the “Input Ext Tamper” terminal on the receiver. This puts the transmitter tamper in the alarm polling network.

The 10.5 to 60 VDC input power can be directly connected to the transmitter and receiver or additional wiring can be included in the connection from the transmitter and receiver to bring power down this line for both transmitter and receiver. Make sure the wire gauge is correct to cover the voltage drop to maintain the correct input voltage.

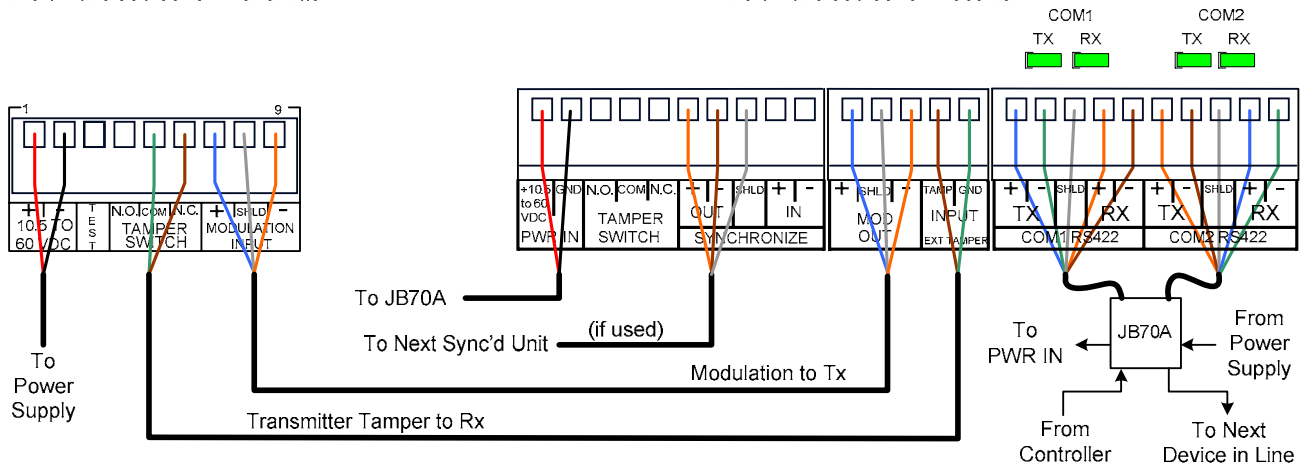

Figure 24 – Tethered Wiring

### 6.4 Synchronized Wiring

If MicroWave 330-33461 is to be synchronized to another MicroWave 330-33461 or Model 380 or Model 385 transceiver it must be in the Tethered configuration. In the synchronized configuration MicroWave 330-33461 supports two (2) time slots, Phase 0 and Phase 1. This will allow for synchronizing two (2) MicroWave 330-33461 links and up to eight (8) transceivers as shown in Figure 25. Two more links can be added if they are rotated 90° as explained in Section 4.2. *Note: Models 380 and 385 are not CE approved sensors.*

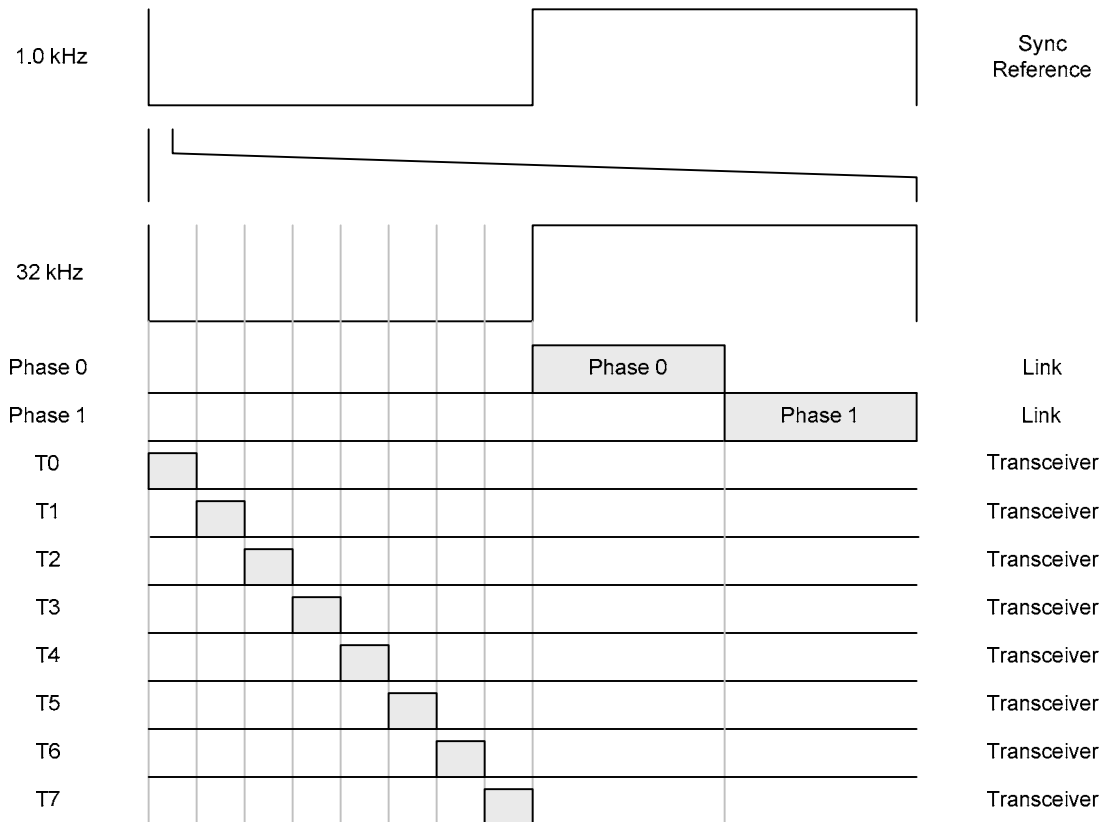

Figure 25 – Synchronization Plan

The synchronization wiring is shown in Figure 26 for two (2) MicroWave 330-33461 links and two (2) Model 380 transceivers. *The Master, Slave, Phase 0 or Phase 1 setting is configured in the UIST II software program.* The synchronization line must use a 22 or 24 gauge twisted, stranded, shielded pair wire. The last unit in the synchronization chain must be terminated with a 120 ohm resistor. For setting the Model 380 or Model 358 in a synchronized mode, please refer to their respective technical manuals. *Note: all other wiring has been omitted for clarity.*

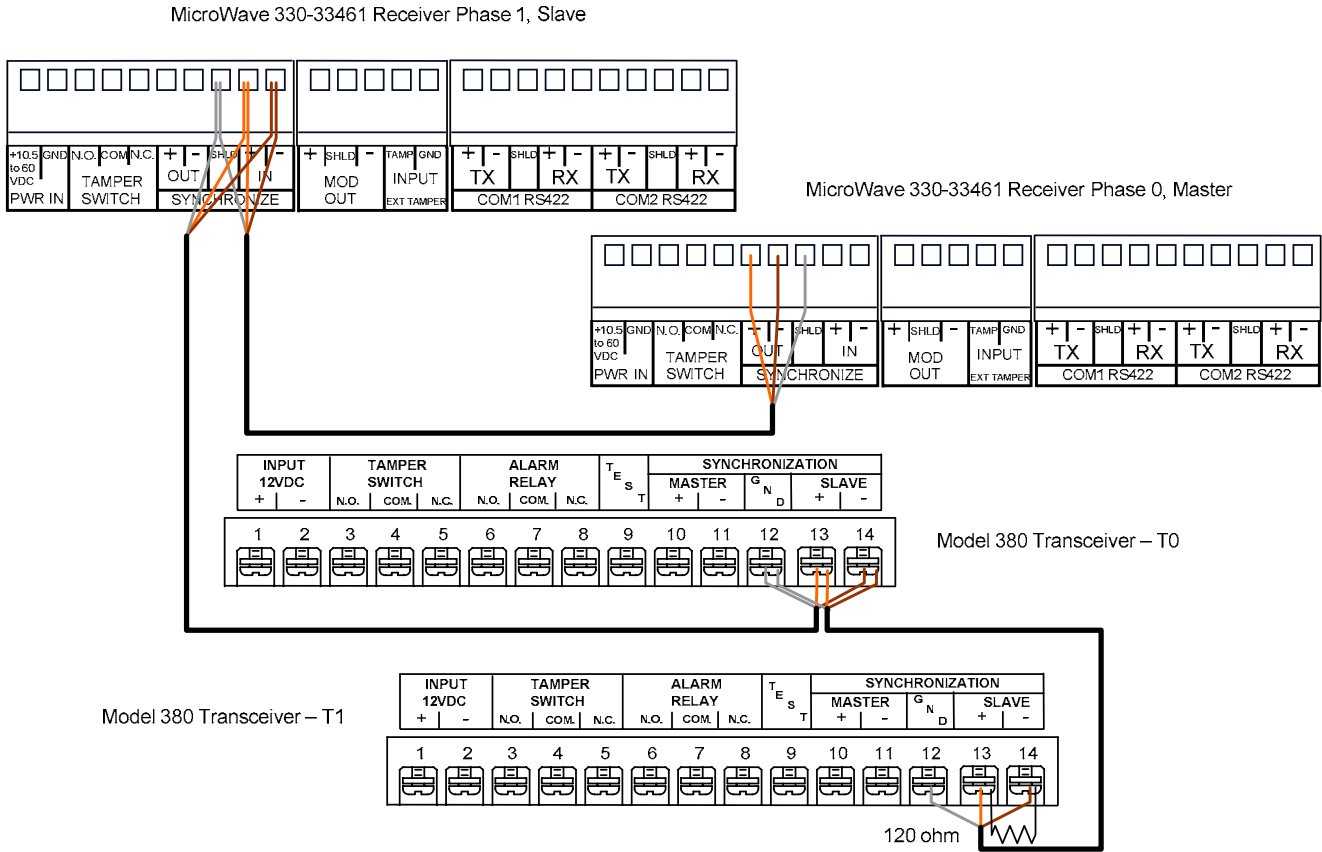

Figure 26 – Synchronization Wiring

## 6.5 Remote Test

MicroWave 330-33461 is equipped with a remote test circuit located on the transmitter. When a voltage, greater than 5 VDC and less than 14 VDC, is applied to the “Test” terminal, the K-band oscillator will turn off as long as the voltage is applied. This loss of signal will cause the receiver to go into an alarm condition. This feature will work in the free running or tethered configuration.

In the tethered configuration, a “test” can be initiated by sending a command over the communications line using the UIST II. The UIST II has a “Remote Test” button which may be activated to exercise this function in the tethered mode. The receiver will process the command and turn off the modulated signal to the tether for a minimum of five (5) seconds causing an alarm at the receiver. The remote test state is stored in volatile memory so that on power-up the remote test feature is inactive.

## 7.0 Terminals, Switches and Indicators

### 7.1 MicroWave 330-33461 Transmitter

The electrical connections, switches and indicators for the MicroWave 330-33461 Transmitter are shown in Figure 27.

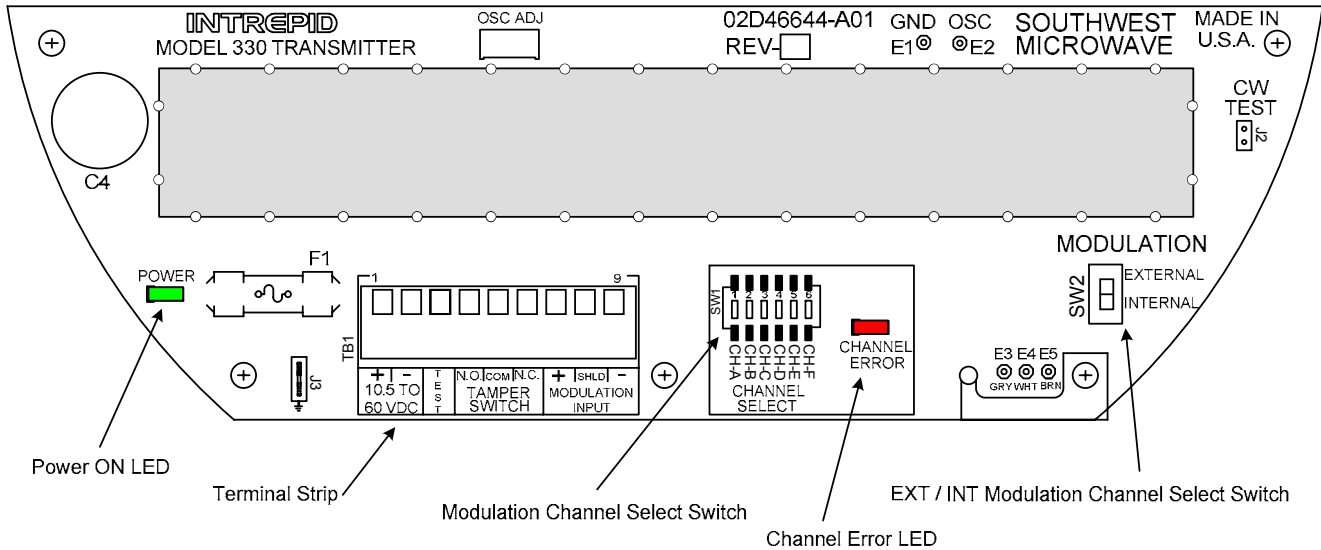

Figure 27 – MicroWave 330-33461 Transmitter

#### 7.1.1 Channel Select Switch

The “Channel Select Switch” SW1 as shown in Figure 28 is used in the Un-Tethered mode to set the modulated frequency of the MicroWave 330-33461 transmitter. The same channel must be used on transmitter and receiver. If transmitter and receiver are on different channels the “Channel Error” LED will illuminate.

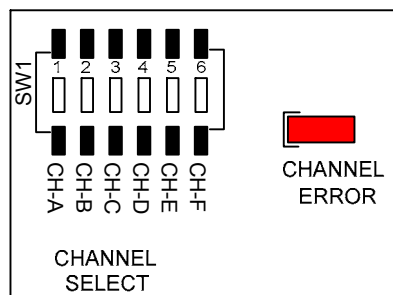

Figure 28 – Channel Select Switch Transmitter

#### 7.1.2 External – Internal Modulation Switch

The “External – Internal Modulation Switch” SW2 as shown in Figure 29 is used in the “Internal” position when in Un-Tethered mode and in the “External” position when used in the Tethered mode. In the Tethered mode the “Mod Out” terminal from the receiver must be wired to the “Modulation Input” terminal on the transmitter and SW2 set to “External” for the system to operate properly.



MODULATION

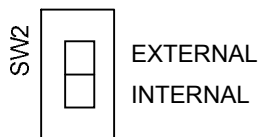

Figure 29 – Internal – External Modulation Select Switch Transmitter

## 7.2 MicroWave 330-33461Receiver

The electrical connections, switches and indicators for the MicroWave 33033461 Receiver are shown in Figure 30.

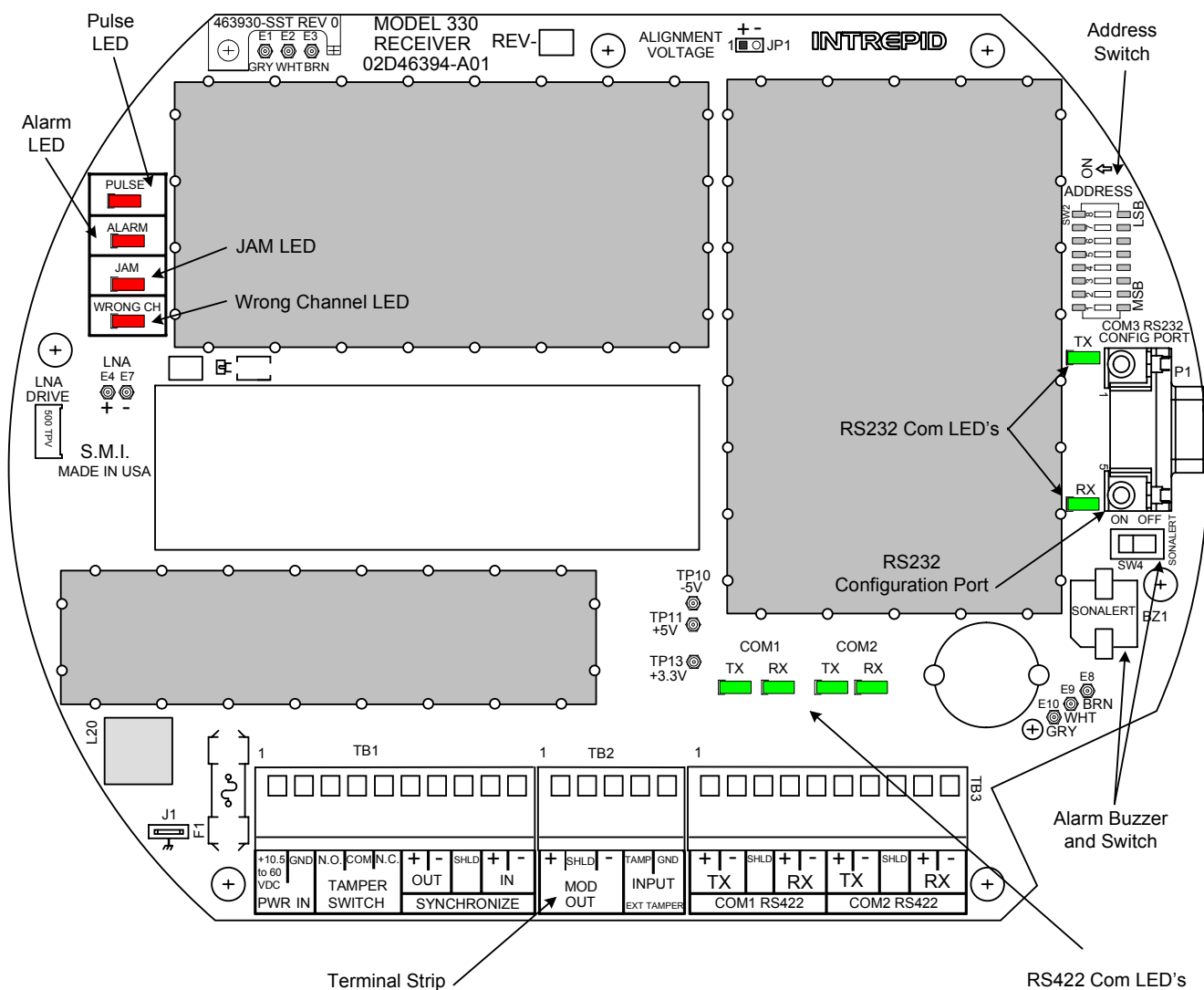

Figure 30 – MicroWave 330-33461Receiver

### 7.2.1 Address Switch

The “Address Switch” is used to set the node address of the MicroWave 330-33461 receiver which is used for the alarm polling by one of the INTREPID™ controllers (RCM II, CM II, GCM II-HD, PSM or SDK). The address can be set from 0 to 239. Switch SW2, as shown in Figure 31, is set by using the **LSB (Least Significant Bit)** as the binary reference starting point for address 1.



Figure 31 – Address Switch

### 7.2.2 Audio Alarm Switch

Each MicroWave 330-33461 Receiver includes an on board “Sonalert” buzzer for alarm annunciation. The audio can be turned on or off by switch SW4 as shown in Figure 32. The switch should be set to “On” when performing intrusion detection tests and set to “Off” when in operation.

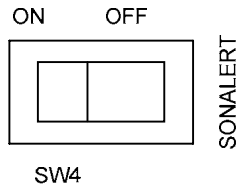

Figure 32 – Audio Alarm Switch

### 7.2.3 Communications Ports

Each MicroWave 330-33461 Receiver has three (3) communications ports. COM 1 and COM 2 are RS422 communications ports. They are used to connect to the controller and to the next device in line for alarm polling. COM 3 is a RS232 dB9 connector and is the configuration port used with the UIST II to setup and configure the MicroWave 330 link. Each communications port has LED’s to indicate communications polling.

## 8.0 Connecting the Transmitter and Receiver

### 8.1 MicroWave 330-33461 Transmitter Connections

**Caution:** DO NOT APPLY POWER UNTIL ALL WIRE CONNECTIONS HAVE BEEN MADE.

1. Remove the radome of MicroWave 330-33461 Transmitter by removing the six-radome screws.

2. Insert power wires, tamper circuit wires, test wires and modulation input wires (if in tethered mode) through the ¾ inch (19mm) conduit fitting. Leave enough slack in wires so that Transmitter may be tilted after radome is replaced.
3. Make connections to the terminal strip according to labeled terminal functions as shown in Figure 27.
4. Attach power wires to terminal identified as 10.5 to 60 VDC + (Positive) and - (Negative). OBSERVE POLARITY.
5. For protection against unauthorized openings or tampering, a Form C tamper switch with a separate set of contacts is provided. Attach tamper wires to the N.O. (normally open), COM (common) or N.C. (normally closed) Tamper Switch terminals per site circuit requirements.
6. Connect Remote Test wire if used, to terminal labeled Test.
7. If configured in the tethered mode connect the “Mod Out” wires from MicroWave 330-33461 Receiver to the Modulation Input terminals. Wiring should be + to +, shield to shield and - to -. The tamper switch from the transmitter should be wired to the EXT TAMPER INPUT on the receiver.

## 8.2 MicroWave 330-33461 Receiver Connections

1. Remove radome of MicroWave 330-33461 Receiver by removing the six-radome screws.
2. Insert power wires; tamper circuit wires, modulation output wires (if in tethered mode) and synchronization wires (if used) through the ¾ inch (19mm) conduit fitting. Leave enough slack in wiring so that receiver may be tilted after radome is replaced.
3. Make connections to the terminal strip according to labeled terminal functions as shown in Figure 30.
4. Attach power wires to terminal identified as PWR IN 10.5 to 60 VDC + (Positive) and GND (Negative). OBSERVE POLARITY.
5. For protection against unauthorized openings or tampering, a Form C tamper switch with a separate set of contacts is provided. Attach tamper wires to the N.O. (normally open), COM (common) or N.C. (normally closed) Tamper Switch terminals per site circuit requirements. A secondary tamper switch is also available that is reported in software using the UIST II to configure and a controller for the alarm reporting.
6. There are no physical relays mounted on the MicroWave 330-33461R receiver. The intrusion alarm output is configured, polled and annunciated using a controller with graphics and /or relays on the RCM II, CM II, ROM II-8 or ROM II-16. Refer to controller (being used) manual and ROM II manual.

**NOTE:** After wiring is completed, it is recommended that entry conduit be filled (sealed) with **non-corrosive sealant such as Dow-Corning #738 RTV. This will prevent moist air in the conduit system from entering MicroWave 330-33461 Transmitter or Receiver.**

## 9.0 Alignment and Testing

The following outline will assist the installer in alignment and testing of the MicroWave 330 Digital Microwave Intrusion Link using a VOM (volt-ohm-meter) with an input impedance of 100,000 ohms/volt or greater. Typical alignment and settings are done using the UIST II software.

1. With radomes removed, apply power to the Transmitter and Receiver.
2. Be sure the identical modulation frequency, channel A through F, is being used on the Transmitter and Receiver in Un-Tethered mode or modulation terminals are connected in Tethered mode.
3. Check for transmitter and receiver operation by monitoring the “POWER” LED on transmitter circuit board and “PULSE” LED. The LED’s must be illuminated.
4. Visually aim the Transmitter and Receiver for “bore-sight” alignment. Aim the transmitter and receiver at each other. Make sure the transmitter and receiver are parallel and perpendicular to the ground plane that is being secured.
5. On the Receiver, voltmeter connected to JP1 “ALIGNMENT VOLTAGE” + and - with meter range set to 1-5VDC can be used to align the link. The alignment can also be done using the UIST II software program which is recommended.
6. Swivel Receiver up and down and side to side, to obtain maximum meter reading. Tighten locking nut on mounting bracket to secure sensor in this position.
7. Raise or lower mounting height of receiver and/or transmitter as required to obtain maximum meter reading.
8. Swivel Transmitter up and down and side to side, to obtain maximum meter reading. Tighten locking nut on mounting bracket to secure sensor in this position. The minimum alignment voltage for the MicroWave 330-33461 is 0.5VDC. Although this is the minimum voltage, proper alignment and mounting height will typically be greater. The peak alignment voltage should range between 0.5 and 5 VDC depending upon link distance. The further apart the units the smaller the alignment voltage.
9. Perform site requirement tests (walk, run, crawl, etc) to determine detection pattern, while monitoring alarm indication by means of the red “Alarm” LED or by the Sonalert on the receiver.
10. Adjust detection parameters using the UIST II until site requirements are obtained. Adjust the “Gain” to optimize the sensor performance to meet detection requirements at the lowest setting possible.
11. Re-install radomes using all six screws.

## 10.0 Preventive Maintenance

MicroWave 330-33461 requires no calibration other than alignment and sensitivity adjustment during installation. To maintain a trouble free system the following is recommended:

1. Wax the radomes every 3 to 6 months using a standard automotive wax. (At maximum security installations, where detection of prone crawling targets is required, wax once a month.)
2. Keep the isolation area clean and free of tall grass, weeds, debris, washouts and obstructions.
3. Upon initial installation, establish a zone data chart. Record input supply voltage, zone distance, transmitter/receiver mounting height, alignment voltage, modulation channel, sensitivity setting, and battery voltages. Also save the “Configuration Report” from the UIST II for reference.
4. If standby batteries are used, they should be functionally tested every three months.

5. A site inspection should be performed every six months. The inspection should include: verifying data from Step 3, checking for physical damage (cracks, leaks, corrosion, etc.) checking for isolation zone changes (washouts, materials placement, vegetation growth, loose fence fabric, etc.)

## **11.0 Limited Warranty**

SOUTHWEST MICROWAVE, INC. warrants each of its products to be free from defects in materials and workmanship. The limit of liability under this warranty is to repair or replace any products or part thereof which shall within one year after delivery to the original user be returned, shipping costs prepaid and insured, to SOUTHWEST MICROWAVE, INC. at its plant in Tempe, Arizona, or authorized Warranty Service Company, and which shall have been found to be defective upon examination by SOUTHWEST MICROWAVE, INC. or authorized Warranty Service Company.

This warranty shall be limited to the repair or replacement of SOUTHWEST MICROWAVE, INC. products and shall not extend to any incidental or consequential damages there from. Disassembly of any product by anyone other than an authorized representative of SOUTHWEST MICROWAVE, INC. voids the obligations of SOUTHWEST MICROWAVE, INC. to repair or replace any products so disassembled.

Excluded from this warranty are fuses and batteries except to the extent that the original manufacturer warrants such parts, and such warranty is marked on the product. Claim under warranty for fuses and batteries should be made by the purchaser directly to the manufacturer.

Warranty returns must first be authorized by SOUTHWEST MICROWAVE, INC. or authorized Warranty Service Company.

SOUTHWEST MICROWAVE, INC. reserves the right to make changes in design on any of its products without incurring any obligation to make the same changes on units previously purchased.

This warranty is the extent of the obligations or liabilities assumed by SOUTHWEST MICROWAVE, INC. With respect to its products and is in lieu of all other warranties, express or implied, including, but not limited to, any warranty of merchantability or fitness. SOUTHWEST MICROWAVE, INC. shall not be liable for consequential damages and its liability is expressly limited to the obligations expressed herein. SOUTHWEST MICROWAVE, INC. Neither assumes nor authorizes any other person to assume for it any other warranty concerning its products.

## **12.0 Returning Equipment under Warranty**

As per the provisions set forth in our Security Products warranty, any person desiring to return equipment to SOUTHWEST MICROWAVE, INC. for any reason, must first contact SOUTHWEST MICROWAVE, INC. for authorization of return.

An authorization number will be issued at the time of authorization, and this number will appear on all correspondence, invoices and credits pertaining to subject equipment.

ALL SOUTHWEST MICROWAVE, INC. sensors and power supplies are provided with a serial number at the time of manufacture. In order to accurately and efficiently supply replacement parts, perform repair service, or issue credit on equipment being returned to SOUTHWEST MICROWAVE, INC., it is essential that SOUTHWEST MICROWAVE, INC. be advised of the serial number of the equipment prior to authorization for return. This notification may be made by telephone or by mail.

## **13.0 Returning Equipment for Non-Warranty Repair**

Return of equipment out of warranty must first be authorized by SOUTHWEST MICROWAVE, INC. at which time a return authorization number will be issued. The returned equipment must be accompanied by an evaluation repair purchase order. Returned equipment will be examined and customer advised of cost of repair or replacement.

## **14.0 Replacement Parts**

To order a replacement or module, specify the complete part number and serial number and address the order or contact us at:

**SOUTHWEST MICROWAVE, INC.**

9055 South McKemy Street

Tempe, Arizona 85284-2946

TEL: (480) 783-0201

FAX: (480) 783-0401

[Infossd@southwestmicrowave.com](mailto:Infossd@southwestmicrowave.com)

[www.southwestmicrowave.com](http://www.southwestmicrowave.com)

